



BULLSEYE INSTALLATION TOOL FOR CYLINDRICAL LOCKSETS

Part Number BULL – Made In USA

Use this tool when locating and drilling cross bore and latch hole when installing cylindrical locks. Before attaching your Bullseye to the door, make sure that the surfaces of the jig are clean and smooth. The tool has two rubber pads that will contact the door face. Be sure they are clean and free of anything that could scratch or mark the door. It is a good idea to wrap the door with a sheet of paper or thin cardboard prior to attaching the jig as a precaution.

Refer to the lock manufacturer's recommended specifications for the height and backset (backset will be changed in the following step) and mark the door accordingly.

Open the Bullseye by turning the Wing Knob (1) counterclockwise so the jig is opened wider than the door thickness. Set the jig for the desired backset by flipping the Backset Tabs (4) away from the door's edge for a 2-3/4" backset or towards the end of the door for a 2-3/8" backset. Position the jig onto the door.

Turn the Wing Knob (1) clockwise until the jig is just touching the door. Turn the Thumb Screw (5) in until it is snug against the opposite Side Plate (9).

Tighten the Lock Nut (6) to maintain this setting. Loosen the Knob (1) and align the Centerline Notch (see drawing) with the height line previously marked on the door and tighten Wing Knob (1) firmly against the door.

If the lock you are installing specifies a 1-1/2" cross bore, leave the Reducer Bushings (7) in place. If it specifies a 2-1/8" cross bore, remove the bushings by loosening the Set Screws (8) with the hex wrench provided.

Using the appropriate bit or hole saw, drill the cross bore halfway from each side. Next drill the latch hole with the appropriate bit or hole saw. Loosen the Knob (1) one full turn and carefully remove the jig from the door. Hint: the strike plate can be located by inverting a 1" hole saw into the latch hole. Shut the door and reach into the cross-bore hole and with a push and twist of the hole saw, mark the door jam.

An additional feature of the Bullseye jig is two 1/8" pilot holes to locate through bolt holes on many of today's popular lever locks. The holes are 2-3/4" apart and work with many popular levers such as Marks, Schlage, Yale and Sargent. Before utilizing the pilot holes be sure to check the lock template and be sure the spacing is 2-3/4", or 1-3/8" from the centerline of the bore. We recommend you use a small drill bit to locate the holes, remove the jig from the door and drill halfway through the door from each side with the appropriate size drill to complete the through bolt holes.

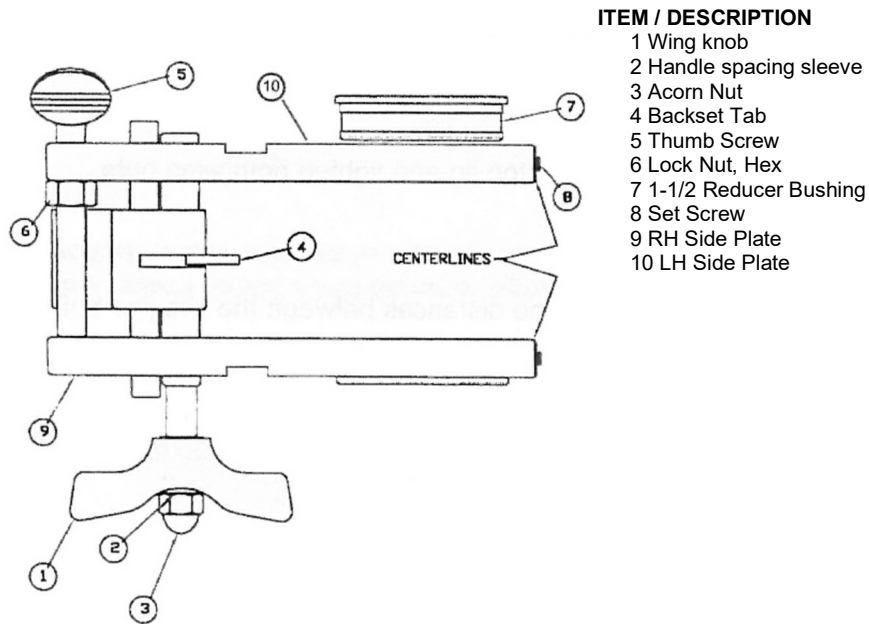

ITEM / DESCRIPTION

- 1 Wing knob
- 2 Handle spacing sleeve
- 3 Acorn Nut
- 4 Backset Tab
- 5 Thumb Screw
- 6 Lock Nut, Hex
- 7 1-1/2 Reducer Bushing
- 8 Set Screw
- 9 RH Side Plate
- 10 LH Side Plate

Using the BLSTRAP Accessories for Interconnected Lock Sets & Dual Bores

Requirements:

A second Bullseye and BLSTRAP interconnecting straps. These tie (2) Bullseye jigs together for interconnected locksets & dual bores.

Refer to the manufacturer's specifications for the center distance between cross bores. Preset each Bullseye by placing on door and bringing the side plates to within one turn of the door faces.

Remove jigs and attach straps as outlined below.

Using the wing nuts supplied, attach the straps to what will be the bottom jig. Example: If you want a 4-1/2" center distance, attach the strap to the bottom jig by placing a wing nut into the hole marked 3-4 and screw it to the side plate with the slotted end of the strap at the top. Repeat for the other side.

Next, Slide the second jig between the straps and place a wing nut through the slot and screw it down until almost tight. Repeat for second side.

Slide the top jig until the 1/2" mark lines up with bottom of the top jig & tighten both wing nuts.

Always double check your setting by measuring the centerline distances between the two jigs before installing the jigs back onto the door.

Follow the Bullseye instructions for mounting to the door.

Framon Manufacturing Company, Inc
1201 W Chisholm St
Alpena MI 49707
www.framon.com
sales@framon.com